



San Diego Ship Modelers' Guild



1126.15 NO. 7.

POND CLOSED	
Feb 16	Aug 17
Apr 27	Aug 31
May 25	Sep 14
Jun 15, 16*	Oct 12
Jul 13	Nov 30
Aug 10	Dec 7

*SDSMG REGATTA

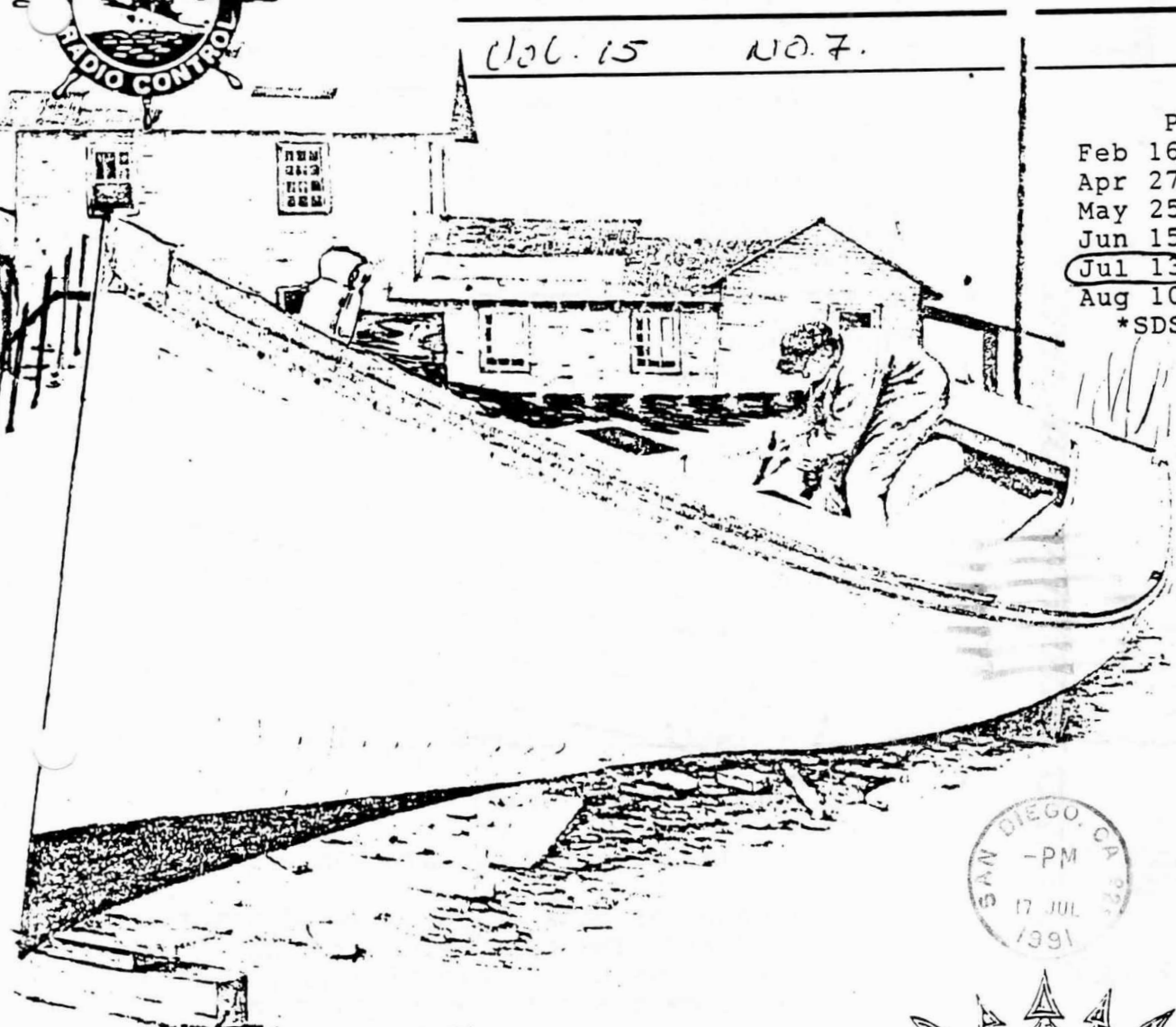

San Diego Ship Modelers Guild
MIKE RIVERA

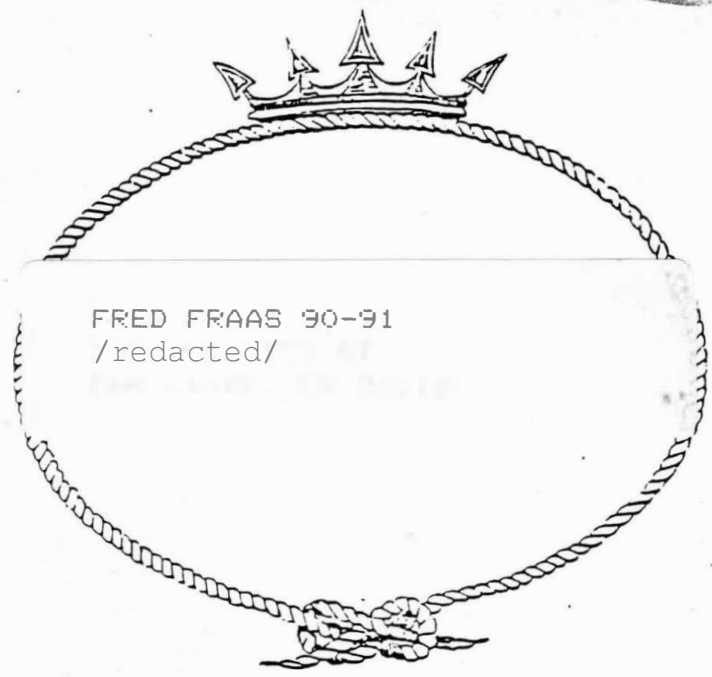

JULY

1	2	3	4	5	6	
7	8	9	10	11	12	13
14	15	16	17	18	19	20
21	22	23	24	25	26	27
28	29	30	31			



Admission to America's Cup Museum



Sailing enthusiasts are invited to discover the history of the America's Cup, the oldest trophy in international sport, by visiting the America's Cup Museum

p.m. daily through May, 1992. Admission is \$5 for adults and \$1 for children 12 and under.

For information, call (619) 685-1412.

The museum, which is located in the Cruise Terminal at the B Street Pier downtown, features an extensive collection of artifacts, graphics and photographs, as well as scale models of every challenger and defender since 1851.

The museum is open from 10 a.m. to 6

Thunderboats

Thunderboats Unlimited, a non-profit organization, has organized the thunderboat unlimited hydroplane races on Mission Bay for 27 years. This year's race will be held September 13-15.

Proceeds from the annual race benefit the Mission Bay Endowment fund. Established by Thunderboats Unlimited, the fund provides for enhancement of park facilities.

ALL REGATTA REPORTS WILL BE POSTED
IN OUR AUGUST NEWSLETTER---LOOK OUT
FOR IT

JULY IS PARTY MONTH:

7-18-91 THURSDAY AT 7:00 P.M.

ABOARD THE STAR OF INDIA BRING SOMETHING TO SHARE, THE GUILD WILL PROVIDE ALL OF THE LIQUID LIBATIONS.....AND MUSIC ON THE STAR UNDER THE STARS.

I HEARD FROM A MODEL SHIP BUILDER IN MEXICO CITY, I GOT SOME PICTURES TO SHOW YOU THAT YOU WON'T BELIEVE, ALSO A NICE FIBERGLASS HULL OFFER FORM ACROSS THE BORDER. CHECK OUT OUR NEXT MONTH NEWSLETTER.

from our friends in L.A. ↓

SHOP MARITIME MODELERS FIRST.

*****Wally Milligan will sacrifice his Chiba Star, 3 cylinder, steam and electric with servo. complete except for radio. Firm asking price, \$575. (He needs the space for his next project) Phone number, 714-521-2352

*****Also for sale: Robbe Japanese PT Boat Kit, 1/40 scale.
Basic kit price: \$149
Fittings set: 79
Total catalog price: \$228 plus tax
Will sell complete outfit for \$125

PRESIDENT

JOHN FLUCK /redacted/

VICE PRESIDENT

BOB WRIGHT /redacted/

TREASURER

BOB WILLIS /redacted/

EDITOR

MIKE RIVERA /redacted/

COMMITTEE

BOB WRIGHT 4redBcEe

ED WHITE d/

JIM HAWKINS /FedacEed/

BOB O'BRIEN 4/redBcE

ed/

SCHEDULE OF ACTIVITIES:

GUILD MEETING THIRD THURSDAY OF MONTH, 7:00 P.M. SOCIAL
7:30 P.M. MEETING

STATIC WORKSHOP - EVERY OTHER TUESDAY 7:00 P.M. TO 9:00 P.M. ABOARD THE FERRY BERKELEY.

R/C OPERATION- SATURDAY MORNINGS MODEL YACHT POND

ANNUAL REGATTA- THIRD WEEKEND JUNE.

MEMBERSHIP:

DUES ARE \$15.00 ANNUALLY

WE STRONGLY ENCOURAGE ALL TO JOIN SAN DIEGO MARITIME MUSEUM AS AN EXPRESSION OF APPRECIATION FOR THE FACILITIES THEY PROVIDE US.

WITH THE JUNE REGATTA BEHIND US WE CAN RELAX A WEE-BIT AS THE SUMMER R/C SEASON BEGINS DON'T FORGET THAT R/C CHANNEL COURTESY IS A MUST, SHOW OFF YOUR CHANNEL COLOR OR LET EVERYBODY KNOW BEFORE YOU TURN YOUR RADIO ON, ARE THE RUNNING TIME.....

TIME TO START NEW PROJECTS LET THE WORD OUT, STEAM?, ELECTRIC?, SAIL?, STATIC?--- WE CAN POINT YOU IN THE RIGHT DIRECTION---IF YOU SHOULD NEED HELP-- OR GET STUCK SOMEWHERE ALONG THE WAY.....

BY THE WAY THIS YEAR WE RECEIVED AN INVITATION FROM THE PEOPLE AT THE DEL MAR FAIR WHICH WE ENTHUSIASTICALLY ACCEPTED. WE HAD A GREAT TIME---EVEN THOUGH THE FOOT TRAFFIC WAS LIGHT WE ANSWERED ALL QUESTIONS AND PASSED AROUND THE GUILD NEWSLETTER TO ALL WHO WANTED TO KNOW WHO WE WERE. THE PEOPLE AT THE FAIR TREATED US GREAT!!! AND WE ENJOYED THE FAIR EXHIBITS, THE FOOD, THE CROWD'S YES IT WAS FUN---EVEN WATCHING SO MANY PEOPLE HAVING FUN---WE SHOULD PLAN OUR EXHIBIT FOR THE FAIR NEXT YEAR WITH AS MUCH DETAIL AS WE DO OUR REGATTA. MORE DETAILS LATER.

WE RECEIVED A LOT OF NOTES FROM OUT OF TOWN CLUB MEMBERS WHO ATTENDED OUR REGATTA, EXTENDING THEIR THANKS FOR ALL THE FUN THEY HAD, AND HOW SMOOTHLY EVERYTHING WENT, THE FRIENDLY CAMARADERIE OF OUR CLUB MEMBERS, TOWARDS OUR OUT OF TOWN GUEST THE TROPHY AWARD PLAQUES WERE A HIT, THE REGATTA PREPARATION'S ON SATURDAY MORNING (AS OBSERVED BY SOME OF THE COMPETITORS) WENT TOGETHER LIKE CLOCK WORK, ONE MINUTE THERE WAS AN EMPTY LAKE AND GRASS, I TURNED AROUND AND PRESTO TENTS WENT UP, TABLES APPEARED FROM I DON'T KNOW WHERE, MODELS WENT ON DISPLAY THE AREA WAS ROPED OFF, SOMEBODY TOOK MY MONEY, GAVE ME A NUMBER, GOOD GRIEF!!! I'M COMPETING IN THE SAN DIEGO REGATTA. AUGHR!!!! AUGHR!!!! THE PRESSURE IS MOUNTING-- THE SUN CAME UP EARLY THIS MORNING, ARE MY BATTERIES CHARGED? THE BULL HORN GOES OFF--- GOOD MORNING???? I DIDN'T SLEEP LAST NITE--- I NEED A DRINK--- A TABLE WITH HOT COFFEE!!! WHO WOULD OF THOUGHT ?!!! I'M READY-- I'LL SHOW THEM ALL --- OFF.... OH NO!!-- I'M BEING CALLED NOW, WHO'S GOT THE NAVIGATION COURSE CHART? HELP!!!!

THIS YEAR OUR COMMODORE ELECTED TO USE AS MUCH OF OUR POND AS POSSIBLE AND OUR NAVIGATION COURSE WAS ONE OF THE MOST INTENSE COURSES I'VE HAD OUR OWN SAN DIEGO TRIANGLE, OUT THERE, WHICH CLAIMED TWO SHIPS, A FOUR STACK DESTROYER, WHO'S CAPTAINS ONLY RECOURSE UPON SEEING HIS COMMAND GOING UNDER WAS A SNAPPY MILITARY SALUTE AND DOWN SHE WENT, THEN THERE WAS THE TUG, ONE OUR MODELING COMMUNITY SEASON CAPT. (WHICH GOES TO SHOW YOU OLD KING NEPTUNE PLAYS NO FAVORITES) THIS TUG BOAT WENT DOWN DEEP---HOW WOULD YOU SCALE DOWN 8 TO 10 FEET OF WATER TO SCALE FATHOMS, UHM!!!? WE ARE HAPPY TO SAY THAT BOTH SHIPS WERE RECOVERED SUCCESSFULLY---THE DESTROYER WENT ON TO SAIL ON THE SAME DAY, THE TUG RETIRED FOR THE DAY....

JIM HAWKINS RECOGNIZES OUR MODELING SKILL---IT'S OUR R/C RUNNING SKILL HE IS AFTER THE ULTIMATE CHALLENGE-- WE DARE BUILD IT, NOW DARE THE DEEP!!! IS NOT EASY TRUSTING YOUR MODEL TO SOMETHING AS UNCONTROLLABLE AS WATER/WIND/SALT/UNDER CURRENTS/R/C INTERFERENCE. JIM WAS UNTIRING RUNNING HERE & THERE PATCHING THIS AND THAT, KEEPING OUR NAVIGATION BUOYS & ISLAND FROM DRIFTING AWAY. HIS PRESENCE WAS EVERYWHERE FROM START TO FINISH.

WE SHOULD HAVE A REGATTA COMMODORE AWARD OF SOME KIND, SINCE I FEEL THE BEST AWARD SHOULD GO TO THE SUCCESS OF THE REGATTA ITSELF AND AS I'VE HEARD SAN DIEGO IS THE PREMIER REGATTA ON THE WEST COAST AND LOOKED UP TO BY MOST CLUB'S AND MODEL SHIP BUILDERS. THE OVER ALL FIRST PLACE IS FOR THE COMMODORE IN CHARGE AND HIS MASTERPIECE THE 1991 SAN DIEGO REGATTA.

JIM HAWKINS

WE THANK YOU!!!!!!

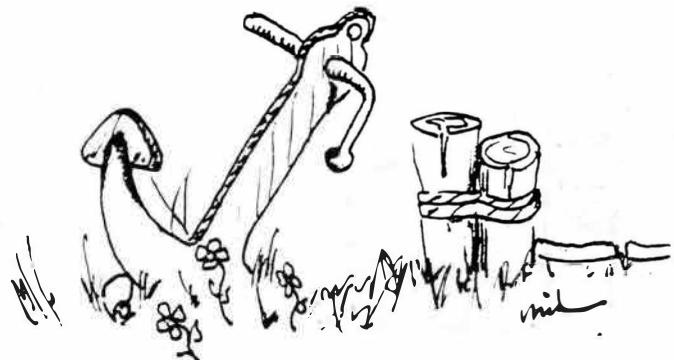

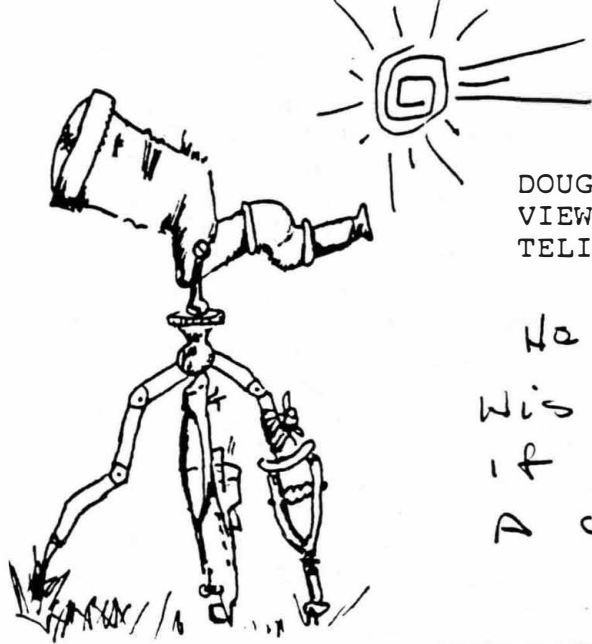

DOUGH MCFARLAND -- TREATED US TO VIEW THE SUN SPOTS THROUGH HIS POWERFUL TELISCOPE.

He is also selling some of his telescope equipment, if interested, give him a call at

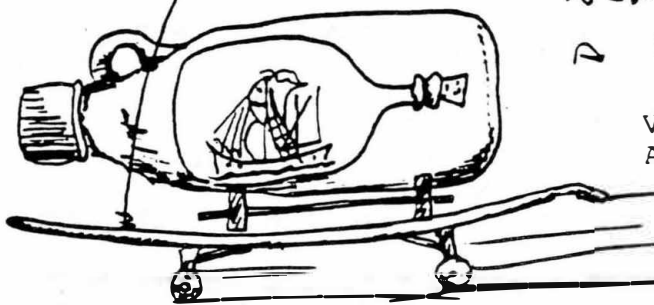

NEXT: SHIP IN A BOTTLE IN A BOTTLE?! ON AN R/C SKATE BOARD...

VIC CROSBY-- SHOWED HIS SHIPS IN A BOTTLE COLLECTION

FOR SALE:

NAUTICAL RESEARCH JOURNALS 1968-79 3 EACH --ALSO INSERTS CONTACT ROBERT TAGGART -- /redacted/

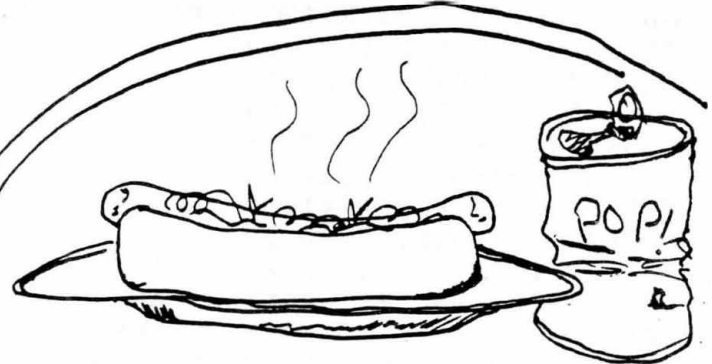

WHO WOULD HAVE THOUGHT THAT HOT DOGS AND POP WOULD HAVE BEEN SUCH A HIT..... IT WAS A WELCOME TREAT AND AN ANSWER TO THE CRY "MID-DAY LUNCH BREAK" WITHOUT LOOSING VALUABLE PARKING SPACE....ALL THE COOKING , WRAPPING SET UP WAS DONE BY THE FOLLOWING GUILD MEMBERS WIVES AND FAMILY: MRS ISABEL WILLIS, MRS. VICTORIA RIVERA & NIECE LIZA AND YOURS TRULLY MIKE RIVERA....THANK YOU ALL FOR YOUR COOPERATION.

NOW! RADIO CONTROL TUG BOAT

EVERYTHING IN ONE PACKAGE

NEW

- A completely detailed Diesel Tug model kit with one piece hull 14 inches long.
- Electronic Speed Control
- Special Motor
- Brass Prop Shaft
- Nylon Props
- Rudder Control Rod & Linkage
- Complete Building and Operating Instructions

Unique is the best description of this first All-in-One R/C model kit. Everything you need to produce a complete Radio Control working model of an HO Scale (1/87) diesel Tug Boat, except the Radio. Any standard two channel radio will work. Everything else is included in the package to make your model complete and at a very special price.
KIT NO. 70817

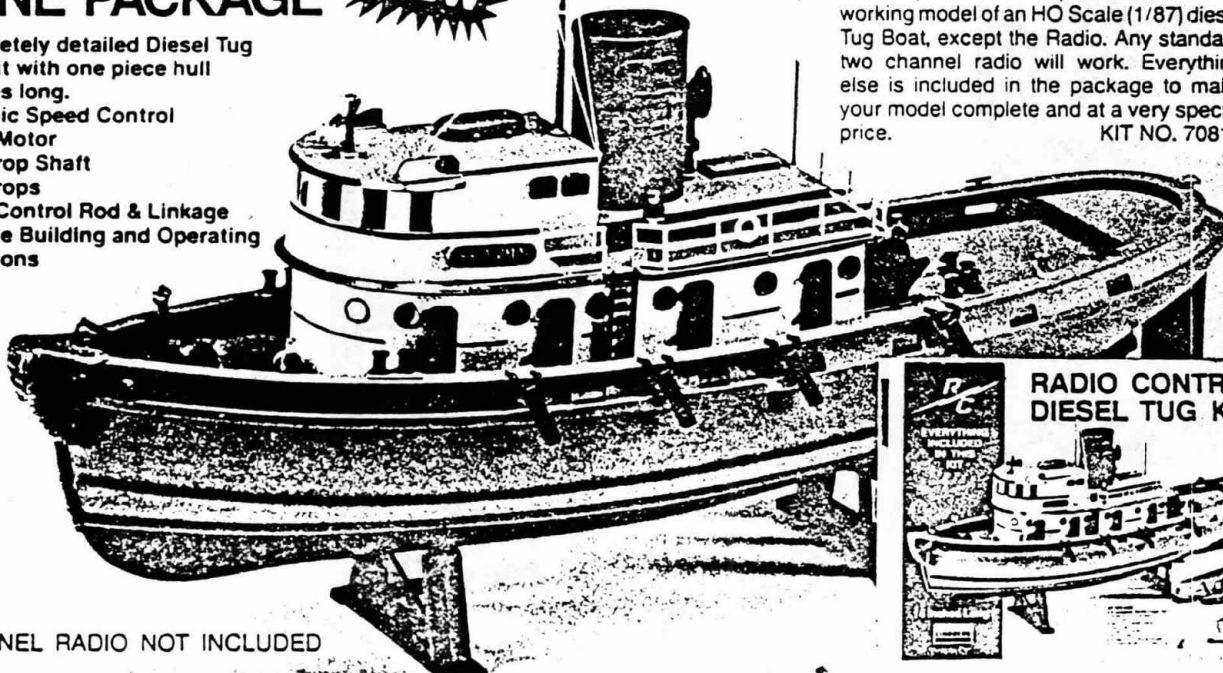

2 CHANNEL RADIO NOT INCLUDED

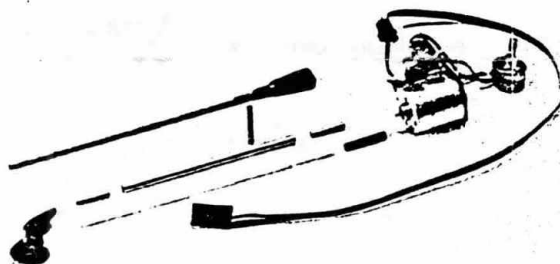

NOW! TWIN MOTOR POWER DRIVE

This all-in one unit turns many large scale model boats into Radio Control models. The set includes:

- 2 Mabuchi Motors
- Brass turned universals
- Aluminum Motor Mounts
- Props
- 5 position speed control with reverse
- Switch & Safety Fuse
- Complete Wiring Harness with Dual Battery Pack Connector

Here is everything you need to Join the R/C hobby.
NO. 78000

This set works with these Lindberg boats,
NO. 70811 Sport Fisherman
NO. 70812 PT 109
NO. 70814 Constellation



Tiny Thumb Planes

AID IN BUILDING MODELS

You can make a whole set for a few cents and will find them invaluable for shaping hulls and similar work

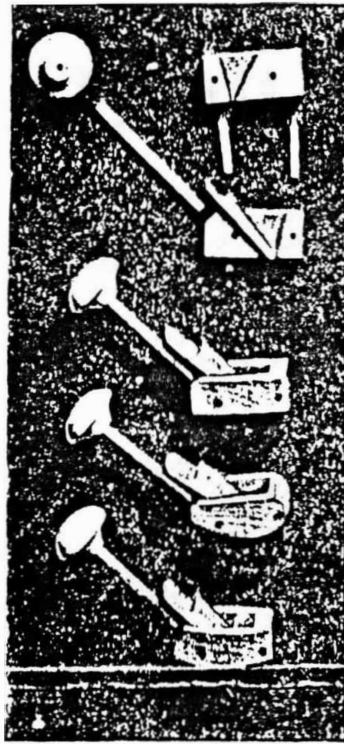

The parts of a thumb plane ready for assembly, and three complete planes with bottoms of different shapes. The body of each plane is made in halves, then doweled

The inside of each block is marked as shown at the right, then slotted with a saw and finished with chisel and file. A round-bottom plane is illustrated below in use on the inner curves of a model sailboat hull

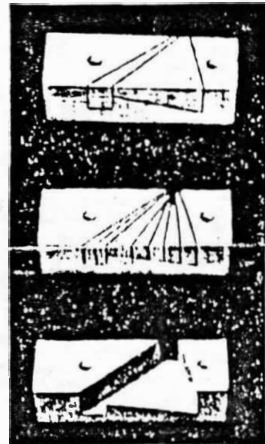
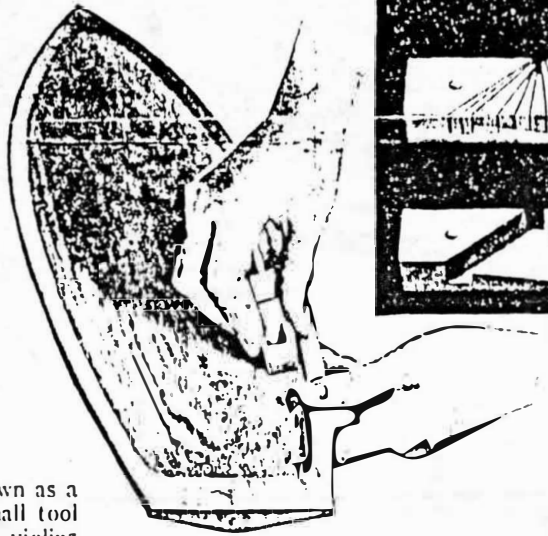

sides can be finished, and then the bottom of the plane can be shaped as you desire—straight, concave, convex, or in any other form.

A palm rest turned to the shape and size shown in the drawing is to be preferred; however, a serviceable rest may be made from a slice of $\frac{3}{8}$ -in. dowel with the top rounded, and a hole drilled in the bottom to take a $\frac{1}{8}$ - or $\frac{3}{16}$ -in. dowel. The wedge is made of hardwood as indicated.

The blade is a piece of hack saw or similar steel, ground and honed to the shape of the bottom of the plane. In setting the plane, let the blade project just a hair from the bottom.

Although the utility of these little tools is more or less obvious, a few of the many jobs may well be mentioned where they will be found to do better work in less time. The flat plane can be used to shape decks, deck houses, and other small parts necessary in making models. The convex or full round is most helpful in shaping the flare at the bow of ship models, also for shaping the inside of ship and sailing models. The concave plane has been found just the tool for shaping masts and yards; it does the work neatly and makes it much easier.

WHAT is familiarly known as a "thumb plane" is a small tool invaluable in making violins and similar musical instruments and in shaping model ships, airplanes, sailing yachts, and the like.

The body of this plane is held between the thumb and forefinger, and the handle cuts against the palm of the hand. With the ordinary plane of this type, the fingers get tired very quickly, but with the new design illustrated, it is possible to work for several hours without undue fatigue or cramps in the fingers because a good deal of the thrust required to push the plane is taken up by the carefully designed palm rest.

The body of the plane is made of two pieces of maple, beech, or some other hardwood with a fine, close grain. Each piece should be $\frac{3}{4}$ by $\frac{5}{8}$ by $1\frac{1}{2}$ in. Clamp them together and drill two $\frac{1}{8}$ -in. dowel holes as shown in the drawing. With the dowels in place, mark the top and bottom of the pieces; then remove the dowels and mark the inside of both pieces. With a small

saw, chisel, and file, remove the waste wood.

When you have finished shaping the inside, the two parts should be doweled and glued together. After the glue has set, the

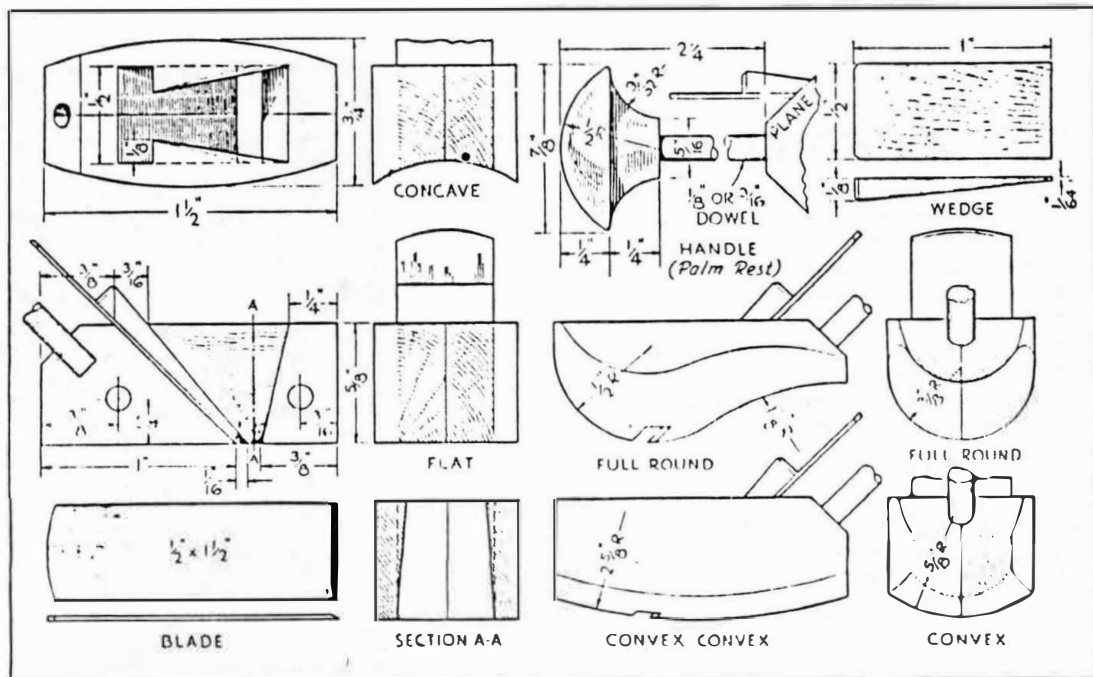

Full-size drawings of thumb planes to show the method of construction and various shapes found useful for models

PRESENTS
TWELFTH ANNIVERSARY-ESCORT SALE

The Scale Shipyard / Warship Hulls Unlimited is celebrating its 12th anniversary with an Escort Sale. Between June 1st and September 1st 1991, when you purchase one or more of the following hull sets with turrets and gun sets, you will receive your choice of a World War II Destroyer or Destroyer Escort for FREE or Half Price, depending on which type of hull that you order during this time. The details for this promotion appear below.

ESCORT SALE-PART ONE

WIIU 17*	USS IOWA (BB-61) CLASS BB WITH SUPERSTRUCTURE MOLDINGS AND PLANS SET.	\$419.00
	BB-61 16" TURRET SET: 3 FIBERGLASS TURRETS, CAST BARRELS AND DETAILS.	109.95
	BB-61 5"-38 GUN MOUNT SET: 10 5"-38 TWIN GUN MOUNTS WITH BASE RINGS.	99.95
	BB-61 DIRECTOR SET: 4 MK-37 DIRECTORS AND 2 MK-38 RANGE FINDERS.	<u>79.00</u>
		\$ 707.90
WIIU 18*	K.M. BISMARCK CLASS BATTLESHIP HULL WITH DETAILED PLANS SET	\$ 319.00
	K.M. BISMARCK 15" TURRET SET: 4 TURRETS, CAST BARRELS & DETAILS	99.00
	K.M. BISMARCK 5.9" TURRET SET: 6 5.9" TURRETS WITH BARBETTS	99.95
	K.M. BISMARCK DIRECTOR SET: 3 MAIN DIRECTORS, 4 BALL TYPE AA DIRECTORS	<u>89.95</u>
		\$ 607.90
WIIU 40*	USS NORTH CAROLINA BB-55 CLASS BB WITH SUPERSTRUCTURE AND PROFILE.	\$ 389.00
	BB-55 16" TURRET SET: 3 FIBERGLASS TURRET, CAST BARRELS AND DETAILS.	109.95
	BB-55 5" GUN SET: 10 5"-38 CAL TWIN GUN MOUNTS W/ BASE RINGS.	99.95
	BB-55 DIRECTOR SET: 4 MK-37 DIRECTORS AND 2 MK-38 RANGE FINDERS.	<u>79.95</u>
		\$ 678.85
WIIU 41*	USS MASSACHUSETTS BB-59 HULL WITH SUPERSTRUCTURE AND PLANS.	\$ 389.00
	BB-59 16" TURRET SET: 3 FIBERGLASS TURRETS, CAST BARRELS AND DETAILS.	109.95
	BB-59 5" GUN SET: 10 5"-38 CAL TWIN GUN MOUNTS W/ BASE RINGS.	99.95
	BB-59 DIRECTOR SET: 4 MK-37 DIRECTORS AND 2 MK-38 RANGE FINDERS	<u>79.95</u>
		\$ 678.95

When you purchase one of the above listed battleship set you will also receive with your order one WW II Destroyer hull of your choice at no additional cost, FREE. The hulls that are available for this offer are:

WIIU / 1	USS FLETCHER	DD-445	WIIU / 9	USS BENHAM	DD-397
2	USS SUMNER	DD-692	10	USS SIMS	DD-409
3	USS GEARING	DD-710	60	USS RUDERDOW	DE-224
4	USS WARD	DD-139	61	USS S.B. ROBERTS	DE-413
5	USS FARRAGUT	DD-348	62	USS BENSON	DD-420
6	USS PORTER	DD-356	80	K.M. FREDRICK III	Z-14
7	USS GRIDLEY	DD-380	81	I.J.N AKIZIKI	
8	USS SOMERS	DD-381	112	K.M. Z-32	

THE ABOVE HULLS ARE THE ONLY UNITS AVAILABLE FOR THIS PROMOTION

ESCORT SALE-PART TWO

When you purchase one of the following battleship hull sets, you can receive one of the listed Destroyer hulls for only \$25.00 with your order. You may choose from any of the escort hulls listed above.

WIIU 72	USS ARIZONA BB-39 HULL WITH DETAILED PLAN SET.	\$ 329.00
	BB-39 16" TURRET SET: 4 FIBERGLASS TURRETS, CAST GUN BARRELS, FACE PLATES & RANGE FINDER HOODS.	109.95
		<u>\$ 438.95</u>
WIIU 74	USS TENNESSEE BB-43 HULL WITH PLAN SET.	\$ 329.00
	BB-43 14" TURRET SET: 4 FIBERGLASS TURRETS, CAST GUN BARRELS AND RANGE FINDER HOODS.	109.95
		<u>\$ 438.95</u>
WIIU 93	USS TEXAS BB-35 HULL WITH DETAILED PLAN SET.	\$ 329.00
	BB-35 14" TURRET SET: 5 FIBERGLASS TURRETS, CAST GUN BARRELS AND RANGE FINDER HOODS.	109.95
		<u>\$ 438.95</u>

(OVER PLEASE)

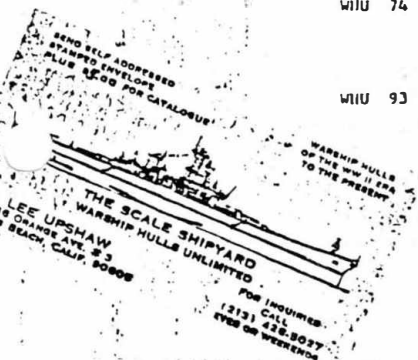

(ESCORT SALE-PART TWO CONTINUED)

WBU 92*	IJN YAMATO JAPANESE SUPER BATTLESHIP WITH PLANS. YAMATO 18" TURRET SET: 3 FIBERGLASS TURRETS, CAST GUN BARRELS AND RANGE FINDER HOODS.	\$ 389.00 <u>139.95</u> \$ 528.95
WBU 71*	USS ALASKA CB-1 HULL WITH PLANS SET. CB-1 TURRET SET: 3 FIBERGLASS TURRETS, CAST BARRELS AND DETAILS CB-1 5" GUN SET: 6 5"-38 TWIN GUN MOUNTS, 2 MK-37 DIRECTORS AND 2 MK-38 RANGE FINDERS.	\$ 329.00 109.95 <u>117.95</u> \$ 556.90
WBU 38*	USS FRANKLIN CV-13 AIRCRAFT CARRIER HULL WITH ISLAND AND 1/16" SCALE PLANS SET. CV-13 5" GUN SET: 4 5"-38 TWIN GUN MOUNTS, 4 5"-38 SINGLE OPEN GUN MOUNTS & 2 MK-37 DIR.	\$ 309.00 <u>99.95</u> \$ 408.95
WBU 39*	USS HANCOCK CV-19 AIRCRAFT CARRIER HULL WITH ISLAND AND PLANS SET. CV-19 5" GUN SET: 4 5"-38 TWIN GUN MOUNTS, 4 5"-38 SINGLE OPEN GUN MOUNTS & 2 MK-37 DIR.	\$ 319.00 <u>99.95</u> \$ 408.95

ESCORT SALE-PART THREE

When you purchase one of the following cruiser hull sets with turrets you can receive one of the listed Destroyer hulls for just 1/2 of the listed price for that escort hull. See current prices in the 1991 Catalog.

WBU 19	K.M. PRINZ EUGEN, GERMAN NAVY HEAVY CRUISER HULL WITH VERY DETAILED PLANS SET. PRINZ EUGEN 8" TURRET SET: 4 CAST 8" GUN TURRETS WITH BARRELS, RANGE FINDER HOODS & BARBETTS.	\$ 219.00 <u>129.00</u> \$ 348.00
WBU 20	USS ATLANTA CL(AA)-51 HULL ONLY CL-51 5" GUN SET: 8 5"-38 TWIN GUN MOUNTS WITH 2 MK-37 DIRECTORS.	\$ 159.00 <u>99.95</u> \$ 258.95
WBU 21	USS OAKLAND CL(AA)-95 HULL ONLY CL-95 5" GUN SET: 6 5"-38 TWIN GUN MOUNTS WITH 2 MK-37 DIRECTORS.	\$ 159.00 <u>79.95</u> \$ 238.95
WBU 22	USS BALTIMORE CA-68 HULL ONLY OR WBU 23 USS PITTSBURG CA-72 HULL ONLY CA-68 OR 72 8" TURRET SET: 3 FIBERGLASS TURRETS, CAST BARRELS AND RANGE FINDER HOODS. CA-68 OR 72 5" GUN SET: 6 5"-38 TWIN GUN MOUNTS AND 2 MK-37 DIRECTORS.	\$ 179.00 69.95 <u>79.95</u> \$ 328.90
WBU 24	USS NORTHAMPTON CA-26 HULL WITH PLANS SET. CA-26 8" TURRET SET: 3 CAST 8" GUN TURRETS WITH BARRELS AND RANGE FINDER HOODS.	\$ 169.00 <u>69.95</u> \$ 238.95
WBU 25	USS INDIANAPOLIS CA-35 HULL ONLY CA-35 8" TURRET SET: 3 CAST 8" TURRETS WITH BARRELS AND RANGE FINDER HOODS.	\$ 149.00 <u>69.95</u> \$ 218.95
WBU 49	USS CLEVELAND CL-55 HULL WITH PLAN SET CL-55 GUN SET: 4 CAST 6" TURRETS WITH GUN BARRELS & RANGE FINDER HOODS, 6 5" TWINS & 2 MK-37.	\$ 189.00 <u>169.95</u> \$ 358.95
WBU 76	USS SAN FRANCISCO CA-38 HULL WITH PLANS SET CA-38 8" GUN SET: 3 FIBERGLASS TURRETS, CAST BARRELS AND RANGE FINDER HOODS.	\$ 199.00 <u>69.95</u> \$ 268.95
WBU 77	USS WICHITA CA-45 HULL ONLY CA-45 8" TURRET SET: 3 FIBERGLASS TURRETS WITH CAST GUN BARRELS AND RANGE FINDER HOODS.	\$ 179.00 <u>69.95</u> \$ 248.95
WBU 78	USS BROOKLYN CL-40 HULL ONLY CL-40 6" TURRET SET: 5 CAST 6" TRIPLE TURRETS WITH GUN BARRELS AND RANGE FINDER HOODS.	\$ 179.00 <u>99.95</u> \$ 278.95
WBU 79	USS HELENA CL-50 HULL WITH PLANS CL-50 6" TURRET SET: 5 CAST 6" TRIPLE TURRETS WITH BARRELS AND RANGE FINDER HOODS. CL-50 5" GUN SET: 4 CAST 5"-38 TWIN MOUNTS (SINGLE PURPOSE TYPE) WITH BASE RINGS.	\$ 189.00 99.95 <u>49.95</u> \$ 338.90
WBU 95	K.M. GRAF SPEE GERMAN HEAVY CRUISER (POCKET BATTLESHIP) HULL WITH DETAILED PLAN SET. K.M. GRAF SPEE 11 TURRET SET: 2 11" FIBERGLASS TURRETS WITH CAST BARRELS AND DETAILS.	\$ 229.00 <u>69.95</u> \$ 298.95

ALL ORDERS MUST BE POSTMARKED NO LATER THEN SEPTEMBER 2 1991. THIS OFFER IS ONLY GOOD FOR HULLS THAT ARE CURRENTLY AVAILABLE, SOME HULLS IN THE CATALOG THAT ARE MARKED 'T.B.A.' WILL NOT BE AVAILABLE PRIOR TO THE CONCLUSION OF THIS SALE, AND WILL NOT BE INCLUDED IN THIS SALE. ONLY THE HULLS IN THIS FLYER ARE INCLUDED.

THIS OFFER IS AVAILABLE ONLY FOR DIRECT ORDERS MADE AND PAID FOR THRU THE SCALE SHIPYARD AND IS NOT APPLICABLE TO ORDERS MADE THRU OTHER DEALERS OR WITH ANY OTHER OFFERS OR COUPONS. NO DEALER DISCOUNTS.

-- FOR ALL OTHER INFORMATION YOU MUST CONSULT YOUR 1991 CATALOG OR CONTACT US --