



San Diego Ship Modelers' Guild

2960 Chicago Street, San Diego, Calif. 92117

Volume 12

Number 12

MERRY CHRISTMAS

December Meeting: Friday, December 16, 1988

7:30 Social - Christmas Party

Orlop Deck of the *Star of India*

Don't bring a model!

Notes from the November Meeting

Our Intrepid Master, Mike Rivera made a gallant attempt to perform a little "organizational dentistry", on our Guild. This was occasioned by the fact that getting members to run for office is a lot like pulling teeth! Alas, after several attempts to "extract" nominations, only two stalwart members agreed to run. Several other members were nominated but declined to run for a variety of reasons. When no further nominations were forthcoming Mike closed the nominations and we settled for a slate of only two candidates. That's the bad news. The good news is that we have two excellent candidates! The candidate who garners the greatest number of votes will be elected the new Master of the Guild. The runner up will become the new First Mate. Bob Hanley has agreed to stay on as Purser to retain some continuity in our financial affairs, and I will continue to publish the newsletter until such time as a new editor can be found. I have enjoyed editing the newsletter for the past ten months, but the demands of my job, especially the amount of traveling involved are making it increasingly difficult to make publishing deadlines. I think it would be in the best interest of the Guild to find another editor who can devote the amount of time to the newsletter that it deserves. For anyone who is interested in trying their hand at it, I strongly recommend that a prime prerequisite be ready access to a word processor. I frankly do not know how Bill Kelley Jr. was able to do it with only a typewriter! Anyway, I will stay on until a new volunteer steps forward.

The candidates for officers for 1989 are:

John Fluck
Doug McFarland

Voting can be done either by mail or at the Christmas party. Votes will be counted and the winner announced at the party and published in the January issue of the newsletter. If you are unable to attend the party and wish to vote by mail you may send your ballot (located elsewhere in the newsletter) to me at the address on the letterhead and I will see to it that your vote is counted at the party. If anonymity is important to you please fold and tape or staple your ballot so it can not be read until all votes are opened and counted. Put your name and return address on the envelope that you mail your ballot in so I can check your name off and insure there is no "ballot box stuffing".

Show and Tell Show and tell produced three items of interest. Bob Crawford brought in the completed main mast assembly for his model of the aircraft carrier *Wasp*. The mast contains a number of intricate photoetched brass components, representing the combined labors of Bob and Albert L'Heureux. Bob says the model is very nearly completed, and takes up most of his living room. For Christmas dinner he estimates it will seat six!

Doug McFarland brought in *Hotspur* to show that the rigging is nearly complete. There are exactly 17 zillion square knots in the ratlines!

Mike Rivera brought in a partially completed Billings kit (?) of a trawler (?) called the *Bohuslan* (?), I think. Anyway it was very nice. (Sorry if I didn't get that right Mike, I was dazzled by all the square knots in Dougs ratlines.)

Hint of the Month For his hint of the month Mike brought in a waterline marker for marking the waterline on model hulls preparatory to painting. Several varieties of these devices have been shown previously, all having some basic characteristics in common. All start out with some form of flat base onto which is attached a vertical support at right angles to the base. A pencil or other marker is then attached to the vertical support in a manner which allows its height above the base to be adjusted for various waterline heights. One way of accomplishing this is to use a length of threaded rod for the vertical portion. Attach the rod to the base and fashion a holder for a pencil that will slide over the rod freely. This can be done with a short section of brass tube of the proper inside diameter to insure a snug fit for the pencil. The tube is then soldered to the edge of a brass washer whose center hole allows it to slide easily over the threaded rod. A nut is used above and below the washer to lock it at the proper height for the desired waterline. A long pencil is needed for ships with a pronounced flair at the bow to be sure the point will be able to contact the hull without the vertical rod coming into contact with the side of the ship.

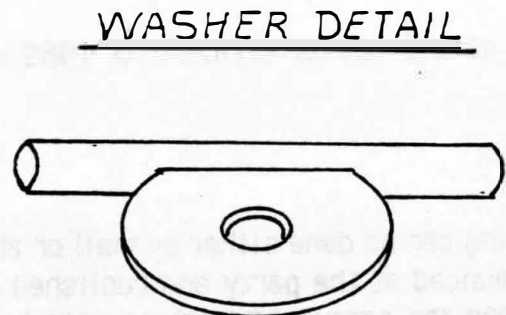
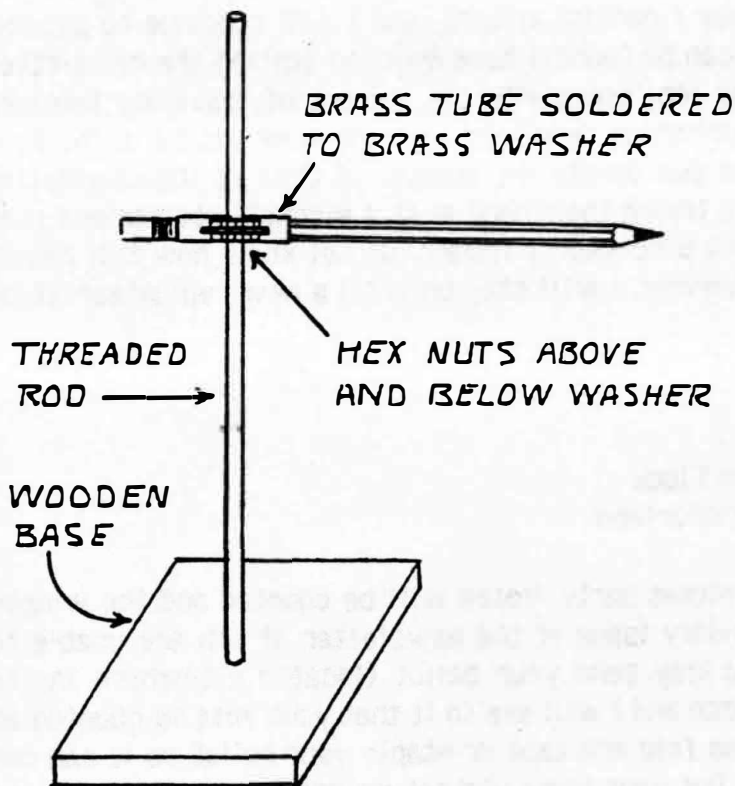

FILE ONE SIDE OF WASHER FLAT.
SOLDER BRASS TUBE TO FLAT SIDE.

Merry Christmas

Christmas Party As in previous years we will have our annual Christmas party on board the *Star of India* beginning at 7:30 on Friday, Dec. 16. Participants are requested to bring their favorite dish to share. Alternatively, the following items are also needed; paper plates, napkins, plastic utensils, soft drinks (the Guild will provide the hard stuff - and a "kitty" will be on the bar for your contributions). Salads and deserts are needed as well as casseroles, chips, dips, etc. All are invited for a great evening of good food and good company in a super setting.



Data Base In addition to the data requested in connection with membership renewals, Bob Cunningham has volunteered to create a special club data base in an expanded format which will allow the inclusion of more information on each member. Bob showed us a preliminary example of what the input sheet would look like and what data it would contain, and requested suggestions from the membership with regard to any other items that we might want to have included. After several suggestions were made Bob agreed to revise the form and have it ready for use soon. A copy will appear in a future issue of the newsletter. The design of the data base should allow for several spin-off lists, such as a frequency list for RC operators. In the meantime everyone is requested to send in the interim data form with your renewed membership. **And don't forget, dues are payable by Jan. 1.** Those not paying up will have their names removed from the mailing list for this fabulous newsletter.

Wasp Project Engineers Chief Engineer Bob Crawford has requested that all *Wasp* project subcontractors get their completed subassemblies (Boats, Flagbags, etc.) to Bob as soon as possible as the project is moving into its final phases.

Classified

Bob Cornell has a four channel (Ch. 62) Futaba radio for sale. No other details available at this time. Call Bob at /redacted/ for price, excessories, etc.

DON'T GAMBLE



**Renew your membership
Now !**

1989 Pond Schedule The November Issue of the Argonauts newsletter contained the 1989 schedule for the pond. A summary of important dates follows. If not otherwise indicated, the normal "open running" schedule is in effect (i.e. sail in the morning, sail in the afternoon).

Feb.

4 & 5 Argonauts, Power - District Heat Races

25 & 26 Argonauts, Power - District Heat Races

April

22 & 23 Argonauts, Sail - Spring Sail Regatta

May

27 & 28 Argonauts, Power - District Outboard Race

June

17 & 18 San Diego Ship Modelers Guild Regatta

July

15 & 16 Argonauts, Sail - Summer Sail Regatta

Aug.

12 & 13 Argonauts, Sail - One Meter Divisional Championships

19 & 20 Argonauts, Power - District Heat Races

Sept.

3 & 4 Argonauts, Power - District Heat Races (Sat.). So. Cal. Scale Thunderboat Race (Sun.)

16 & 17 Argonauts, Power - Southern California Scale Thunderboat Race

Oct.

14 & 15 Argonauts, Sail - Fall Sail Regatta

Dec.

9 & 10 Argonauts, Sail - SCRS #4

Happy Chanukah

Meilleurs Voeux

Presidents Day Regatta Ray Agee announces that there will be a Presidents Day Regatta in Pheonix on Feb. 19, 1989. He says the site of the regatta, located on a turnoff off I-10 near Tempe, is "fantastic"! Inexpensive motels (Motel 8's, etc.) are within a quarter of a mile, and R.V.'s can park overnight without any problems. Reportedly there are a large number of shopping opportunities for the ladies in the vicinity also. Ray expects the regatta to draw over 100 entries in six categories; Military, Pleasure, Working, Submarines, Steam and Sail. Special events will be held for "juniors" (under 18). Models will be judged on workmanship and authenticity and operating models will be required to navigate a predetermined course. Sponsors are being gathered and Ray says the prize list will be impressive. If all goes well this will become an annual event and may eventually have a corporate sponsor. It's about a ten hour drive to Pheonix, but I hear it is lovely in February. It would be nice to hear that members of the San Diego Ship Modelers Guild came back with our share of the gold! From all indications other clubs in Southern Calif. will be represented



INTERNATIONAL MODELER SHOW

P.O. Box 10127, Costa Mesa, California 92627-0031 Phone: (714) 548-4700

I.M.S. MODEL CONTEST

Prizes, Prizes, Prizes
Trophies, plus 1st, 2nd, and 3rd Place Ribbons
in all categories plus "Best of Show"

**SHOW DATES, 1989: Thursday, January 12 (Set up), Friday, January 13 (Trade-Only),
Saturday, January 14 (Public), Sunday, January 15 (Public).**

CONTEST RULES

All entries are free, open to all ages, no limit on number of categories entered, but only one entry per category. Contestant must be builder of model. All entries must be brought to the ANNEX entrance of the Exhibition Building, Pasadena Center, Pasadena, California, on Thursday, 10 a.m. to 8 p.m., or Friday, 10 a.m. to 4 p.m., or Saturday 10 a.m. until noon. The Exhibition Building Annex entrance is located on the lower parking level of the Pasadena Center. This is the ONLY entrance at which models will be received. Exhibitor ramp/entrance is for exhibitor unloading only. Models that are heavy and/or require assembly at delivery must be brought in on Thursday only. Those entering models on Saturday morning must pay regular admission charge, as show will be open. **ENTRIES CANNOT BE ACCEPTED OTHER THAN AT TIMES STATED ABOVE.**

ENTRIES MAY NOT BE PICKED UP BEFORE 4:30 P.M., SUNDAY. All entries must be removed from the Center by 7 p.m., Sunday. Models will be guarded while on display, however, IMS accepts no responsibility for loss or damage to entries. The hold-harmless agreement must be signed before entry will be accepted. Contestants are not granted free admission to the show during regular show hours, except on Sunday, after 4 p.m., when contestant may enter at no charge to pick up model (by showing model claim check to gate attendant).

SAVE ENTRY TIME: Send SASE for a Model Entry Form. If entering more than one model, or for a friend who wishes to enter, machine copies of form will be accepted.

BEST OF SHOW

Best Finish, Aircraft
Best Original Design, Aircraft
R/C Race Boat, Electric
R/C Race Boat, Gas
R/C Scale Boat/Ship, Military
R/C Scale Boat/Ship, Pleasure
R/C Scale Boat/Ship, Work
R/C Boat, Sail (AMYA Class)
R/C 1/10 Offroad Car
R/C 1/12 Road Car
R/C 1/8 Offroad Car
R/C 1/8 Road Car
R/C 1/4 Scale Grand National
R/C 1/4 Scale Sprint/Supermodified
R/C Glider, Scale
R/C Glider, Aerobatic/Stope

R/C Glider, Thermal
R/C Electric, Old Timer
R/C Electric, Sailplane
R/C Electric, Scale
R/C Electric, Sport/Pylon/Pattern
R/C Old Timer
R/C Pylon
R/C Scale, Giant
R/C Scale, Precision Military
R/C Scale, Sport Military
R/C Scale, Precision Non-Military
R/C Scale, Sport Non-Military
R/C Sport/Scale Helicopter
R/C Sport Biplane
R/C Sport/Pattern
Control Line Scale

Control Line Speed
Control Line Stunt
CO₂ Sport/Scale
F/F Endurance, Gas
F/F Endurance, Glider
F/F Endurance, Rubber
F/F Old Timer, Gas
F/F Old Timer, Rubber
F/F Scale, Power
F/F Scale, Rubber
Rocket, Static
Rocket, Flying
Plastic Aircraft
Plastic Boats/Ships
Plastic Cars
Plastic Trucks

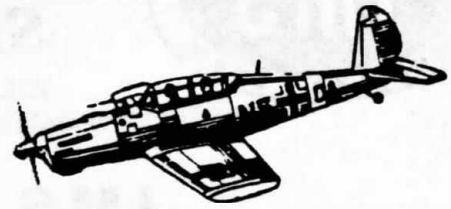

THE 12TH ANNUAL MODEL SPORT & HOBBY SHOW

SATURDAY, January 14, 1989, 10AM - 6PM

SUNDAY, January 15, 1989, 10AM - 5PM

Pasadena Center, Pasadena, California

HOME OF THE FAMOUS ROSE PARADE & ROSE BOWL

300 East Green Street (Corner of Green & Marengo) Pasadena, CA 91101

SEE THE LATEST PRODUCTS AND VISIT WITH

MAJOR MANUFACTURERS AND DISTRIBUTORS

- MODEL AIRCRAFT
- MODEL ENGINES
- MODEL BOATS
- RADIO CONTROL SYSTEMS
- MODEL CARS
- MODELING ACCESSORIES

SPECIALIZING IN RADIO CONTROL

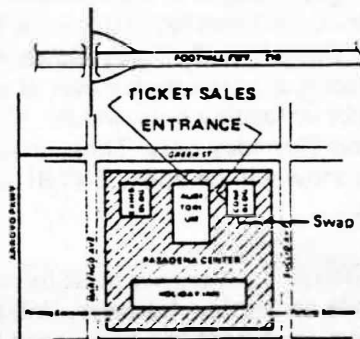

INDOOR DEMONSTRATIONS

STATIC DISPLAY COMPETITION IN MANY CATEGORIES

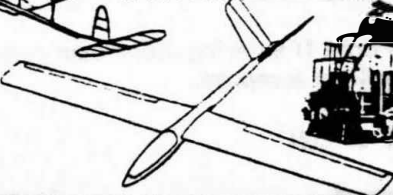

SEE LIVE INDOOR RADIO CONTROLLED MODEL AIRCRAFT BLIMP,
BALLOON CAR BOAT AND RAILROAD DEMONSTRATIONS

ADMISSION: Adults \$5.00, Juniors (12 and under) \$3.00.
Children under six admitted free when accompanied by an adult.

SWAP SHOP: Bring your saleable items to the Swap Shop. NO DEALERS, PLEASE! Table rent: \$30.00 for two days, includes one admission. You are responsible for your own sales. IMS is not responsible for lost or stolen items.

Bring your children, so they can learn to build and fly a MODEL AIRPLANE during the show!

BEST in the WEST!

★ GIANT RAFFLE! ★ SWAP SHOP!

STATIC MODEL COMPETITION: Entry is free, open to all ages, no limit on number of categories entered per contestant, but only one entry per category. Contestant must be builder of model. Trophies and ribbons awarded in over 50 categories. Send SASE to IMS office for list of categories, competition rules, and advance entry form.

GIANT RAFFLE: Radio control systems, kits, engines, etc., will be raffled off Sunday at about 4:00p.m., other prizes during course of show. Tickets on sale both days. You need not be present to win Giant Raffle items. Proceeds to be donated to charitable organizations.

INTERNATIONAL MODELER SHOW Office: P.O. Box 10127, Costa Mesa, CA Ph: (714) 548-4700

World Shipyard Orders Up "The world order book for new ships is at its highest point in two years, according to the London-based Lloyd's Register of Shipping. The total tonnage either under construction or on order at the end of the second quarter of 1988 increased by 754,464 gross tons to 23.97 million gross tons, which according to Lloyd's, is the highest figure in two years. According to Lloyd's, South Korea had the largest share of the world order book, registering a 27 percent share. Japan came in second, with over 24 percent. Other nations showing increases include the People's Republic of China, Yugoslavia, and the Federal Republic of Germany." Tony Beargie in American Shipper, November 1988, quoted in Seapower

USSR's First Aegis Ship "The Soviet Kiev-class carrier *Baku* emerged from the Turkish Straights in June equiped with a new radar suite, including a phased-array search radar. The antenna.....consists of four rectangular panels, each about five meters by five meters (i..e. slightly larger than those of the U.S. Aegis SPY-1).....This system replaces the Top Pair long-range, three dimensional air-search radar in the three earlier ships of the class. It is the first Soviet fixed-array search radar to go to sea.....Unlike earlier Kiev-class ships, the *Baku* has no long-range anti-aircraft missile. Instead, she has only a vertically launched point-defense missile.....That suggests that area air defense may be entrusted instead to the fighters the ship carries, perhaps successors to the current daylight-only Yak-38 Forger. If that is the case, it is more significant than the radar development." Norman Friedman in Naval Institute Proceedings, October 1988.

One Torpedo, One Carrier? "New Soviet torpedoes, armed with conventional warheads, have become so explosive that one hit could put a large American aircraft carrier out of action, according to a U.S. Navy assessment. The finding, which was included in a report on what must be done to retain Navy supremacy in the 21st century, asserted that the Soviet Union has "an imposing torpedo arsenal when analyzed from any aspect: variety, capability, warhead size, or quantity." ... The report said the Soviet navy appears to be emphasizing torpedoes rather than cruise missiles launched from submarines or surface ships. That finding represents a change from five years ago, when American naval officers said cruise missiles were the greatest threat to warships." Richard Halloran in the New York Times, 9 October 1988, quoted in Seapower.

HAPPY NEW YEAR

**BONNE
ANNÉE**

**Felices
Fiestas**



San Diego Ship Modelers Guild
Doug Smay, Editor
/redacted/



102.05
2705
75.00

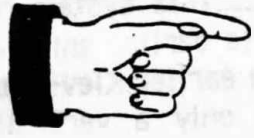
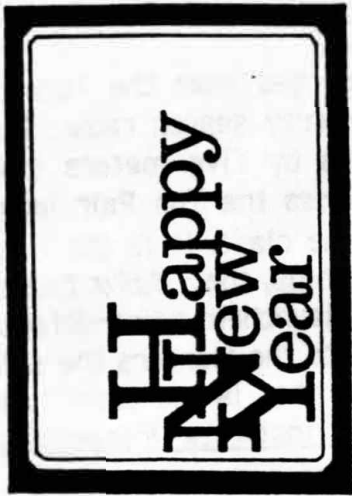

**San Diego Ship Modelers Guild
Officers for 1988**

Master
Mate
Purser
Logkeeper
Newsletter Editor
Steering Committee

Mike Rivera /redacted/
Roger Smith
Bob Hanley /redacted/
Tim Pettit 4/redacted/
Doug Smay /redacted/
Norm Hiatt /redacted/
Doug McFarland
Roy Nilson /redacted/
Fred Fraas

Schedule of Activities

Meetings - Third Friday of the month
7:30 PM social, 8:00 PM meeting
Staic Workshops - Every other Tues.
7:00 to 9:00 PM aboard the ferry Berkeley
R/C Operations - Saturday mornings
Model Yacht Pond
Annual Regatta - Third weekend in June

Membership

Dues are \$10 annually

We strongly encourage all to join the San Diego Maritime Museum as an expression of appreciation for the facilities they provide us.

MERRY CHRISTMAS