



San Diego Ship Modelers' Guild

VOLUME 9. NUMBER 4

APRIL 1984

ALMA

Scow schooner ... operated along with hundreds of similar shallow draft sailing scows carrying bulky commodities in the Bay and up the Bay rivers.



"One could not be lonely in a sea like this."

-Joshua Slocum

"How serene to be alone on a well-loved boat on an easy beam reach in smooth water."

William Robinson

APRIL MEETING

SPECIAL DATE FRIDAY, APRIL 13, 1984

Our April meeting will feature a presentation on the CALIFORNIAN Project. Bruce Gordon from the Project's scoweer's bureau will show us slides of the progress of the construction and tell us about various aspects of the project. Bruce and his wife Harriet have been friends of my parents since ... well for a long, long time, and I guarantee that Bruce will give a very informative and entertaining presentation. Those of you who missed our program at the construction site last October will have a chance to learn about this great project, while those of us who did get to the site will find this presentation to compliment our previous experience. This will be one of those programs that spouses and friends may find interesting, so bring them along.

REMEMBER THIS MONTH'S MEETING IS A WEEK EARLY -- APRIL 13
BRING A MODEL -- BRING A FRIEND

***** INSIDE THIS ISSUE *****

LOG OF THE APRIL MEETING

Regular Features:

"CALIFORNIAN" UPDATE
FROM THE CROW'S NEST

News about models and from
the waterfront

NEWS FROM OTHER CLUBS
CALENDAR OF EVENTS

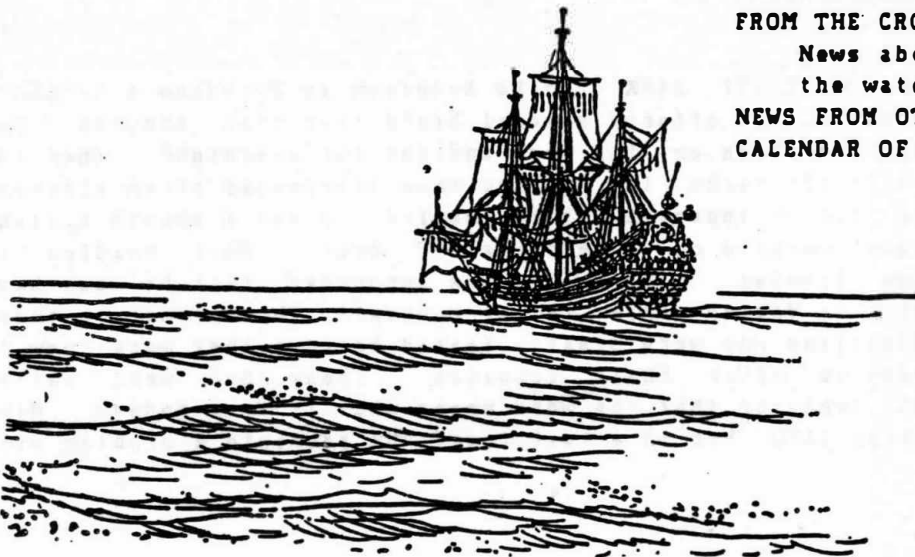

LOG OF THE APRIL MEETING

Master Roy Nilson called us to order around 8:00 P.M. on the Orlop Deck of the STAR OF INDIA, and welcomed four visitors, Ed Sakariassen, Magary Damico, Dick Ekenberg, and Albert Francis.

SPECIAL ANNOUNCEMENTS: The Lookeeper had several items which had been brought to his attention. The Maritime Museum has another in its lecture series for members on March 21, featuring the movie, "Down to the Sea in Ships." Correspondance from the Lee Duvall of the San Francisco group has been received informing us of their regatta schedule (see elsewhere in this newsletter). Their "Crowley" tug event is judged by real tug captains. A draft of the club directory was passed around so members could check for accuracy of the listings. The Purser's report indicates our treasury has a balance of \$454.61. Bill Benson reported that Hillcrest Hobbies was going out of business as of today, and that Leroy will be going into Balboa Hospital for gall bladder surgery soon. The Lookeeper will send him a card.

OLD BUSINESS: The Ship Modelers Association in Fullerton has changed their regatta to May 20. Master Nilson reminded members that if they want a nametag, to get their orders into him.

NEW BUSINESS: Albert reported that preparations have begun for the regatta. A dry run will happen a week or two ahead. Albert was given several files of past notes that had been dug up. There will be some work needed ahead if time. Bill Kelly-Fleming reported that most of the lines for the bouys were shot after being pulled out of the water after the last regatta. Master Nilson also called on the members to submit material for the newsletter to help the Lookeeper out.

SHOW & TELL:

Vic Crosby

CALIFORNIAN (POF at Spanish Landing) in a bottle

Doug McFarland

HOTSPUR

Masts being installed

Roy Nilson

PC (sub chaser)

Hull of this blanked hull, scratch built

3/16"=1' model. It will be an RC operating model. The hull is made of balsa and Bondo. He has installed his prop shaft, with the oil tube being made out of telescoping brass which is welded after being put into place in the hull. Most of these vessels were built at Wilmington and at Newport Beach. Roy also had some samples of styrene which he uses extensively in his models.

Bill Kelly-Fleming

NEWSBOY

A brigantine from a Model Shipways kit.

Hull has been coppered, and deck furnishings started on this solid hull model.

TITANIC

A 4 1/2 foot card model. The hull has been

completed and the boat deck is being worked on. This is a very interesting variation on our hobby. (It is very unforgiving in that if you make a mistake you can't just go and carve out a replacement part!)

Magary Damico

PT BOAT

From the Lindberg kit. This is his first RC

boat and looks very nice.

Member project updates:

Les Gibbon is working away on his CUTTY SARK. Mike Anderson is building a CROCKETT and is ready for fiberglassing. Albert offered several hints for that process. One key is to put the first coat of resin on the wood and let set overnight. Then the next day, while it is still slightly tacky, lay on the thin fiberglass cloth starting at the keel. By using a this "tacky" approach, it is easier to get a smooth finish. Bruce Jamison and his son are working on a Higgins PT Boat. Phil Headley is continuing work on his fishing trawler. Albert Lheureux announced that he may have decided on his next project: a Viking ship (RC of course)! The oarsmen on these ships were very strong Scandinavians who were greatly feared because they were known to leave captured towns in shambles after their rampages. These men were called "berserks" and it is from their behavior that the word means what it does today. Mike Dory is working on his submarine GATO, but in a test today, he ran into a problem with

his watertight box which apparently wasn't! He talked about various failsafe systems for submarines. Bill Benson reminded us of the invitation to see his latest project on March 24, the cable repair ship ZUES. He has been working on that project for over 15 months. He also is working on producing a kit of the MEDEA in 3/16" scale using a moulded hull and John Woodard fittings. He hopes to have the kit of this display model available by Christmas. And finally, Fred Frass is working on the YORKTOWN for the Aerospace Museum, and is now building up the island. He had some of the gun mounts to show us. Fred also told us about his collection of old movies which use ship models, especially movies about WWII.

PRESENTATION: Doug McFarland demonstrated his modified and motorized rope-walk on which he can now do serving. It is fast and produces excellent results.



Californian

PROJECT UPDATE

With launching less than two months away, progress on this historic ship is reaching an exciting and climatic point. I had a chance to look at some great photographs of the early days of construction. I was reminded of how much work has passed since I first stopped by that fenced in beach area last July 3rd. The current calendar calls for placing the last hull planks on and sealing the hull about April 12, and for launching about 2000 hours on May 28. While Sacramento is to be her port of registry, it appears that San Diego will be her official home port.

We will all get a chance for more of an update at our April meeting when Bruce Gordon of the CALIFORNIAN Project will be with us to present our program.

Here are excerpts from my personal log of the project:

MARCH 22: The rudder has been removed in order to add the gudgeons and pintles. Notches are being cut in the appropriate points in the rudder post to accommodate the pintles. Several members of the work crew are continuing work on sanding and smoothing out the hull. One man is working on the base of the main mast, shaping and sanding. In particular he is shaping the base so it will accept an iron ring. Meanwhile, a few yards away, another worker is rotating the jib boom as he shapes, sands, and smooths it out. Over at the work shed, blocks are being painted white and the welder is working on another tank. Two long planks are sent inside the hull through the opening which is still left. On deck there is a flurry of activity, but I cannot determine what is being done from my vantage point.

MARCH 28: Within the past 24 hours the jibboom has been shipped, standing out prominently from the bow. I can see four or five workers lifting a large hatch cover into place over the great cabin aft. Work on smoothing, painting, and caulking the hull continues as before. One worker uses a chain saw to cut a 3-foot section off of a large beam of mauchiche for some project. The planking on the deck of the foc's'l is complete and is receiving finishing touches. Through a gun port I can see the winches on the side of the foremast fife rail. In the shop area, the metal loops are being added to the blocks, and several workers turn over one of the tanks for further welding. It is quite hot from sitting in the sun.

APRIL 3: The dolphin striker and the chain from the end of the bowsprit to the waterline of the bows have been installed. The catheads have been added in the past several days, complete with a golden Bear's heads on each tip. Some of the trim paint on the trail boards has been done. The woodcarver's work bench was piled high with blocks. I counted 18 small blocks (about 4-6"), over 70 regular sized single blocks and 6 double blocks.

CALENDAR OF EVENTS

#

#	APRIL 7	all day	Crew Classic, Mission Bay
#	APRIL 13	8:00 p.m.	Regular Guild Meeting, SPECIAL DATE THIS MONTH:
#			CALIFORNIAN Presentation
#	APRIL 14-15	all day	Museum Rummage Sale
#	APRIL 28		POND CLOSED: Spring Sail Regatta
#	APRIL 28-29	all day	MAC SHOW, Long Beach
#	MAY 5	10 - 3	MEMBERS DAY at the Museum
#	MAY 11-20		SCMA/SEA WORLD Boat Show
#	MAY 18	8:00 p.m.	Regular Guild Meeting
#	May 20	all day	SMA REGATTA, Fullerton
#	May 23	7:00 p.m.	Museum Membership Program: "The U.S. Merchant Marine"
#	May 26		POND CLOSED: District Outboard event
#	MAY 28	8:00 p.m.	CALIFORNIAN launching
#	June 10	all day	"CROWLEY CUP" tug boat skills event, San Francisco
#	June 15	8:00 pm	Regular Guild Meeting: Annual Birthday Party
#	June 23-24		SAN DIEGO SHIP MODELER'S GUILD ANNUAL REGATTA

NEWS FROM OTHER CLUBS

SAN FRANCISCO MODEL YACHT CLUB REGATTA/EVENTS SCHEDULE

Power Squadron Regattas for Club Points (all at 9AM):

April 15, July 22, August 12, and October 14.

Monthly Meetings, 8PM at club house in Golden Gate Park:

Every second Thursday

JUNE 10, 9AM, "CROWLEY-CUP" Tug boat skills event.

OCTOBER 28, 9AM "DAGO-REGATTA" (final Power Sqdrn. Regatta)

Logkeeper has complete schedule, including sail regattas.

From the SMA in Fullerton comes a notice of the Association of Model Submariners. There are over 100 members in the USA and all over the world. There is a quarterly newsletter full of useful information and tips. It is primarily a postal club with an annual subscription of 5.00. Members also receive interesting catalogues and brochures appertaining to the world of submarines. A joint rate of 6.50 for husband/wife, father/son, family memberships is also available when one newsletter is sent per household. For a membership application write to Roger Serpell, 25, Onslow Road, Richmond, Surrey. Jack Elem also has information. Write him /redac#ed/ /redac#ed/

Are you going to be in New England in mid April? The U.S.S. CONSTITUTION Model Shipwright Guild of New England is hosting a special meeting at Mystic Seaport on Saturday, April 14. Several clubs from the Northeast will provide a speaker to present a topic of interest to modelers, sort of an "All Star" program of club presentations.

WAPAMA

*Steam schooner . . . built to
replace vessels like
the THAYER . . .
carried lumber and passengers
between California ports and
the Pacific Northwest.*



FROM THE CROWS NEST



If it's April it must be MAC show time! The show will be on Saturday and Sunday, April 28-29 at the Long Beach Convention Center. Models to be entered in the show can be delivered on Friday between the hours of 10 A.M. to 8 P.M. at the Convention Center, 300 E. Ocean Blvd. in Long Beach.

In San Juan Capistrano they tell Spring is here by the return of the swallows. In my native New England it is the return of the robin. But on the San Diego waterfront it is the bending of the first sail on the STAR OF INDIA. In the past few weeks this has happened with the three newest sails being bent, the two royals and the fore-t'gallant.

The arrival of the VIKING PRINCESS and her accompanying hydrofoil has been delayed until at least April 14. There has been a controversy over her operations as related to the casino on board.

I recently received the PRIDE OF BALTIMORE Commemorative issue of their newsletter. Her voyage which brought her to the West Coast and San Diego departed Baltimore on October 31, 1982 and returned over a year later on November 19, 1983 at 1600 hours, one year and 19 days out! Our Congratulations to the skippers and crew. We here in San Diego enjoyed her two visits here.

Congratulations and a "Well Done" to Loren Perry for earning a Gold Medal at the highly prestigious Model Engineer Exhibition in Wembley, England. The award was in the working model ship in a scale under 1:48 class D-2 and was for his U.S.S. VOGELGESANG.

As you may recall the same model walked off with top honors at our regatta last Fall. Loren has recently been named as editor of SCALE SHIP MODELER and we look forward to his influence in that magazine. Good luck Loren!

Several of our members enjoyed the opportunity to see Bill Benson's cable repair vessel ZUES on March 24. As usual Bill did an excellent job on this impressive model. We were also happy to see John Woodard who stopped by. John is doing great now, but cannot get out to many social events. He is getting back into doing a little bit of casting, and as reported at our last meeting, will be casting fittings for Bill's MEDEA kit.

Our model submariner, Mike Dow, has been seen on the TV news and quoted in the newspapers recently as a Sheriff's Dept. spokesperson from the North County. My "reporter in the field" said that he had to take a second look since none of us have ever seen Mike in uniform!

Several of our members will be traveling this summer and visiting maritime sites. How about taking some notes while on your trip and reporting back to the Guild. It would be really great if we could get a few articles for our newsletter. Pictures would be especially welcome.

ONE MORE REMINDER: IF YOU WANT A NAME TAG WITH OUR COLORFUL LOGO, GET YOUR ORDER IN TO ROY NILSON.

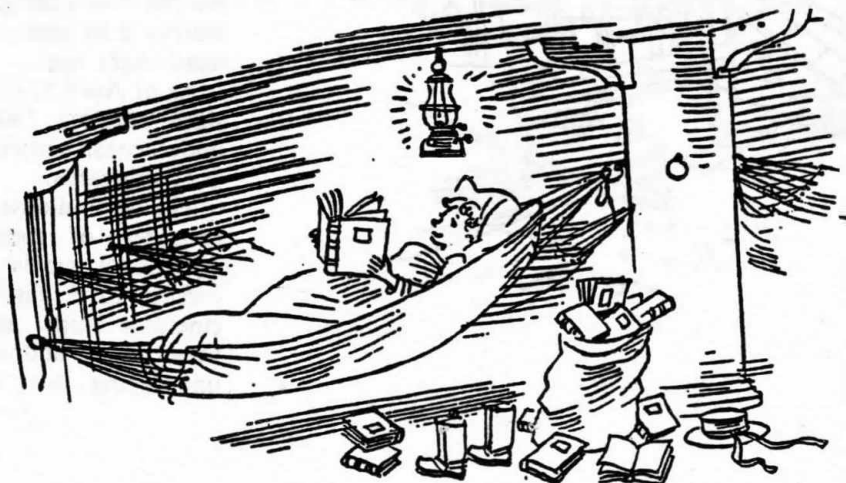

TOPICS REQUESTED BY MEMBERS

1984

Printing and name plates

How to: -Fiberglass.

-Radio Control

-Protecting of working models
in salt water: paints, seals...

-Setting up of electrical
systems... how to best get
rid of unwanted radio interfer-
ence... what is best 6V or 12V?

HOW TO's and WHERE TO BUY

MORE HOW TO TALKS.

R/C Sail Design

All phases of model construction
techniques (3)

Possibly mfr reps for tools

History, How to research (2)

Building static historic sailships,
rigging, planking

1983

Name Plates (printing)

Fiberglassing (2)

More ships in bottles

Plastics and metals

Paint, weathering

Military models

Sail making

Speed controls

Gear ratios

Steam

Types of wood

Plans from scratch

Steam Engines

Rigging

R/C installation

Elementary electronics

Making Shrouds even

Wives feeling left out



From MARINE DIGEST

U.S. FLEET CAPACITY GROWS

WASHINGTON, DC — The privately owned, deep-draft fleet of the U.S. Merchant Marine totaled 712 vessels with a carrying capacity of about 24.8 million deadweight tons on April 1, according to a report that was recently released by the Maritime Administration.

The total comprises 569 oceangoing ships and 143 Great Lakes vessels.

Compared with April 1982 totals, the number of ships in the U.S. fleet decreased by six oceangoing vessels but the fleet's carrying capacity was increased by approximately 147,000 deadweight tons.

As of April 1, 1983, 16 merchant ships totaling 540,780 dwt were under construction or on order in U.S. shipyards.

The shipbuilding orderbook then consisted of eight tankers, one intermodal carrier, one dry-bulk carrier, three tug/barges, two incinerator ships, and one research vessel. One additional vessel was undergoing conversion.

WOOD LATHE by LEE STOKLEY • S.M.A.

- (A) (1 x 2) x 3" • END FRAME
- * (B) (1 x 1) x 2 3/8" FIN. • D'WL REST
- (C) 3/8" x 2" x 2" • D'WL STIFFENER
- (D) (1 x 2) x 24" • D'WL BASE
- * (E) 3/8" x 2" x (4 1/2" & (6") LONG • ADJUSTABLE TAIL STOCK
- (F) (2 x 6) x 3 1/2" • LATHE BASE
- (G) 1/2" DOWEL x 24" • TOOL REST
- (H) (2 x 4) x 3" • DRILL REST

- * Ø HOLE HEIGHT ESTABLISHED BY Ø DRILL CHUCK TO BE LEVEL.
 - TAIL STOCK MAY BE SECURED BY SCREW INTO BASE OR SLOTTED TO RECEIVE CARTRIDGE BOLT/NUT THRU DIFF. LOCATIONS IN BASE AS SHOWN.
 - TAIL STOCK HOLE(S) SIZED TO WORKING STOCK USED. (DRILL IN POSITION)
 - USE WELL DRIED WOOD - GLUE & NAIL FIXED JOINTS.
- DRWG SHOWN FROM REAR FOR CLARITY.

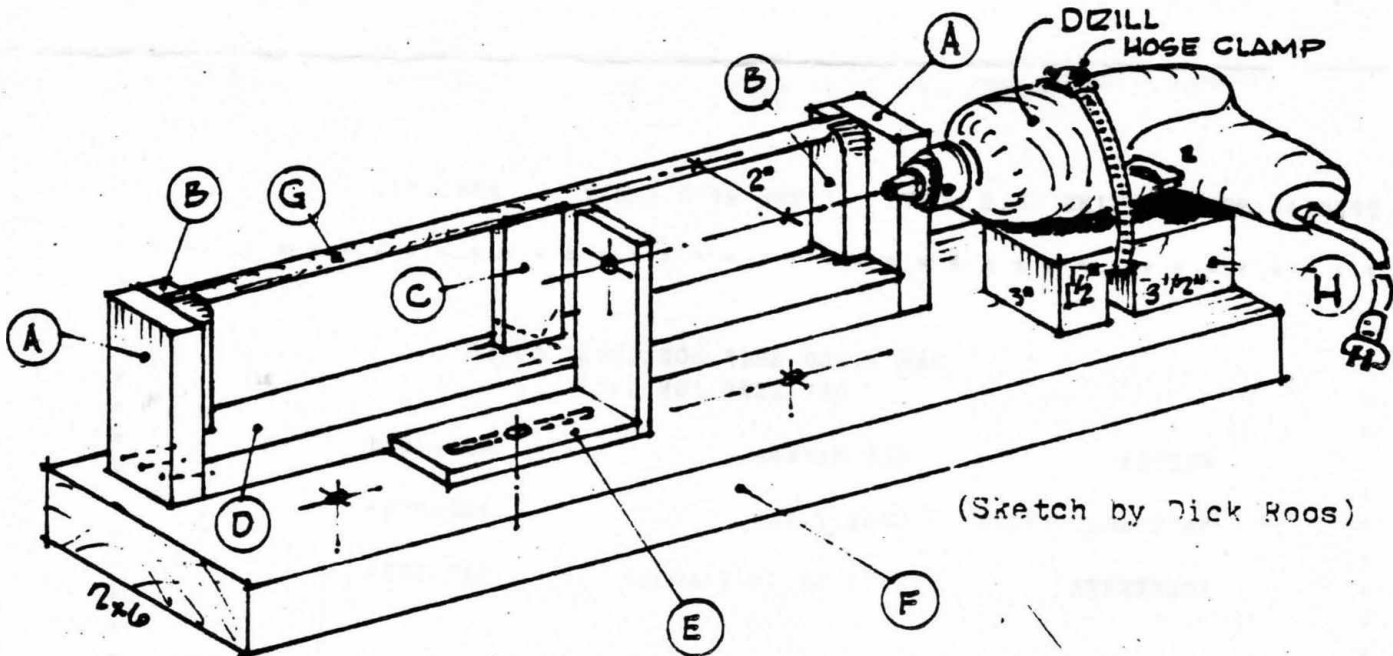

Shoplifted from the Newsletter of Ship Modelers Association, Fullerton, Calif. (C'mon you guys, if they can send in hints to their editor almost every month why can't you fellas do it?????)



San Diego Ship Modelers' Guild
Bill Kelly-Fleming - Lookkeeper
(redacted)

TO: FRED V. FRAAS

(redacted)

SPECIAL MEETING DATE:
APRIL 13 ONE WEEK EARLY

SPECIAL MEETING TIME THIS MONTH ONE WEEK EARLY APRIL 13

SAN DIEGO SHIP MODELERS' GUILD
OFFICERS FOR 1983

MASTER	Ray Nilson	(redacted)
MATE and PURSER	Fred Fraas	(redacted)
LOGKEEPER	Bill Kelly-Fleming	(redacted)

MEETINGS: 3rd Friday of each month, 8:00 p.m. aboard the Bark STAR OF INDIA, on the Orlop Deck.

MEMBERSHIP: Dues for Members of the San Diego Maritime Museum* and anyone living outside of San Diego County - \$7.50. Non-Museum Members - \$15.00. After July* the dues are 1/2 for the remainder of the year *

